

## T Series

### Product Model: TC-3-A1000-JD9.5-XD100-6-IN2.5-OUT0.15-003

The flexible Rogowski coil current sensor enables precise measurement of alternating current while providing electrical isolation between the primary and secondary circuits. Its advanced winding technology significantly reduces positional errors of the measured conductor within the aperture, enhancing the sensor's immunity to external magnetic interference.



### Characteristic

- The performance of the flexible Rogowski coil complies with the GB/T 20840.10-2025 standard.
- The voltage ratio is 1000 A/100 mV.
- The integrator is equipped with a shielding layer, effectively reducing common-mode interference from small signals.
- The coil features 100% conductive fabric shielding, while the aluminum foil and woven copper wire provide dual shielding for the signal cable, ensuring 100% protection.
- Protection rating: IP68.

### Merit

- It is easy to install in applications with limited space.
- It offers excellent measurement accuracy, with a fixed position accuracy class of 0.5S.
- It does not saturate due to overcurrent or short-circuit current.
- It possesses exceptional electromagnetic anti-interference capabilities.

### Apply

- **Power Protection, Control, and Monitoring Applications:**
  - Monitoring of the medium and high voltage switchgear protection system.
  - Motor overload/short-circuit protection monitoring.
  - Monitoring of grounding faults in large, complex conductors.
  - Arc fault current monitoring (arc light protection).
  - Power fault indicator, transmission line fault diagnostic device, traveling wave ranging detection.
- **Power quality analysis and governance monitoring scenario:**
  - Grid harmonic monitoring.
  - Active filter sampling.
- **Special industrial current monitoring applications:**
  - Measurement of the secondary-side current in calcium carbide furnaces and electric furnace transformers.
  - Current measurement for power-frequency and medium-frequency welding machines.
- **High transient pulse current measurement:**
  - capacitor discharge .
  - Lightning current detection.

- **High-voltage insulation condition monitoring:**
  - Insulator leakage current measurement.
- **Measurement of power electronic devices:**
  - Rectifier current measurement.
- **The applications of high-speed rail primarily focus on the following two key areas:**
  - Real-time monitoring and protection of the traction converter and power circuit.
  - Precision protection for the auxiliary power supply system.
- **Charging station sector:**
  - Real-time power monitoring and flexible regulation enable precise measurement of the charging station's current power in real time, with data transmitted to the control platform.
  - The upgrade of outdated charging piles, serving as a critical measurement component, forms part of the renovation plan together with the "guide rail gauge" and concentrators.
  - Enables precise billing and charging control to prevent overcharging and overdischarging, ensuring battery safety and charging efficiency.

### Standard

- IEC 61010-1:2010
- IEC 61010-2-32:2012
- GB/T 20840.10-2025/IEC 61869-10:2017
- IEC 60664-1

safe



matters need attention

If this current sensor is not used in accordance with the manufacturer's product operating instructions, its protective functions may fail. Before use, carefully inspect the current sensor unit and connecting cables. Do not use the device if any damage is detected (e.g., exposed sections of flexible cables).

The installation components must ensure that the maximum temperature of the primary busbar meets the specified requirements, satisfies the electrical clearance and creepage distance, and minimizes electrical and magnetic coupling. Unless otherwise specified in the specification, the components may be installed in any direction.



Be careful of electric shock

This product is intended for electrical installations in restricted access areas and must not be handled during normal operation. Only qualified personnel are permitted to handle it during installation or maintenance.

This product must be connected to the input terminal of a Safety Extra Low Voltage (SELV) device, with a maximum input voltage of 30 V RMS.

During operation, certain components of the current sensor may carry hazardous voltages (e.g., the main busbar, power supply).

Before installing the product, disconnect the power supply to all circuits and hazardous live components.

All installation, maintenance, repair, and operational procedures must be performed by trained professionals in compliance with relevant safety precautions.

Igoring this warning may result in personal injury or severe damage.

After installation, the hazardous live parts of this current sensor must not be touched. The current sensor must be installed at an appropriate terminal position.

Exercise extreme caution when installing, operating, or disassembling this product. The interior of electrical equipment may contain high voltage, high current, and elevated temperatures (exceeding 70°C). Personal protective equipment (such as clothing and gloves) must be worn.

This current sensor should not be cleaned with detergents. However, if the user must perform cleaning or washing procedures, they must independently verify the appropriate cleaning protocol.

Do not dispose of this product as unclassified municipal waste. Contact a qualified recycling facility for proper disposal.



Risk of electric shock

Do not install or disassemble this product around uninsulated hazardous live conductors, as doing so may cause electric shock, electric burn, or arc flash.



ESD vulnerability

The product is prone to damage due to electrostatic discharge events; operators must ground it before handling.

**Attention!**

Do not damage the coil. Actions such as forceful twisting, piercing, excessive squeezing and over-bending will greatly reduce the accuracy and service life of the equipment.

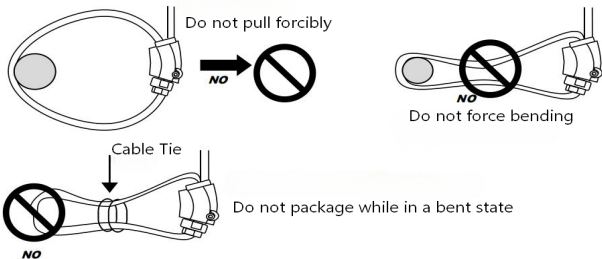

**ries maximum rated value**

Parameter	Symbol	Unit	Value
Maximum secondary voltage	$U_{sr \max}$	V	30
Maximum single-conductor temperature	$T_{B \max}$	°C	105

Exceeding these rated values may cause permanent damage to the product.

Prolonged exposure to environments exceeding the maximum rated values may reduce product reliability.

**insulation coordination**

Parameter	Symbol	Unit	≤price	Remarks
The RMS voltage for AC insulation testing is 50 Hz, lasting 1 minute.	$U_{rms}$	kV	7.4	
Impact withstand voltage: 12/5 μs	$U_{imp}$	kV	12.8	
Root Mean Square (RMS) test voltage for partial discharge (qm <10 pC)	$U_t$	kV	1.65	According to IEC 60664-1
Electrical clearance (primary-secondary)	$d_{cl}$	mm	>16	The shortest distance in the air
Crawling distance (primary-secondary)	$d_{cp}$	mm	>16	The shortest path to the device body
Sheathing material			V0	According to the UL94 standard
Compared to the leakage current trace index...	$CTI$		600	
Application Example Root Mean Square Voltage Between Lines		V	1000	The basic insulation complies with the IEC 61010-1 standard, CAT IV, PD2.
Application Example Root Mean Square Voltage Between Lines		V	1000	The insulation meets the IEC 61010-1 standard for CAT III, PD2.
Voltage Insulation		V	2000	Coil
		V	6000	Signal cable

**Environmental and Mechanical Characteristics**

Parameter	Symbol	Unit	Least value	Representative value	Crest value	Remarks
Environmental operating temperature	$T_A$	°C	-40		100	
Environmental storage temperature	$T_{A \text{ st}}$	°C	-50		100	
Relative humidity (non-condensing)	$R_H$	%			80	
Above sea level		m			4000	
Quality	$m$	g		401		

### Electrical Data

TA = 25°C, RL = 5 kΩ, unless otherwise specified.

Parameter	Symbol	Unit	Least value	Representative value	Crest value	Remarks
Maximum current	$I_{MAX}$	A		100K		
Rated primary current	$I_{pr}$	A		1000		
Transmission Ratio	$k_r$	A/mV		1K/100		@50Hz
Rated frequency	$f_R$	Hz		50		
Rated secondary voltage	$U_{sr}$	mV		100		@50Hz, $I_p=1000A$
Coefficient of mutual inductance	$M$	nH		484.2		
Frequency Bandwidth (-3 dB)	$B_W$	Hz	1		20K	
Angle deviation <sup>1)</sup> @50Hz	$\Delta\varphi$	'			12'	
Inductance of coil	$L_s$	mH		1.142		
Coil resistance	$R_s$	Ω	50		250	
Difference (center position 5)	$\varepsilon$	%	-0.05		0.05	2) <sup>4)</sup> Figure 1
Difference (vertical positions 1, 2, 3, 4)	$\varepsilon$	%	-0.50		0.50	2) <sup>4)</sup> Figure 1
Difference (tilted positions 1, 2, 3, 4)	$\varepsilon$	%	-1.00		1.00	2) <sup>4)</sup> Figure 2
Degree of linearity	$\varepsilon_L$	%		0.1		
Error caused by external magnetic field interference	$\varepsilon_{l\ ext}$	%	0	±0.2	±0.4	<sup>3)</sup>
AC withstand voltage: 50 Hz, 1 minute		kV			4	
Temperature drift		%			0.5	
DC component	$U_{DC}$	mV			0.1	
(Integraler) Operating voltage	$U_{ar}$	V				
(Integraler) Power Consumption	$P$	W				

Note:<sup>1)</sup> The main phase offset is 90° (the Rogowski coil is a current-generating sensor).

- 2) Consider a dominant body with a minimum thickness of least  $\varnothing 15$  mm, positioned vertically and in contact with the Rogowski coil.
- 3) Use an external conductor with a minimum diameter of  $\varnothing 15$  mm, matching the current level of the internal conductor, positioned vertically and in contact with the Rogowski coil.
- 4) Vertical position error:

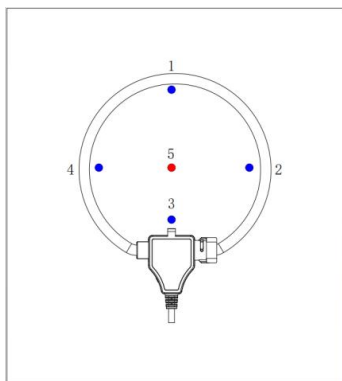

Figure 1

Inclination position error:

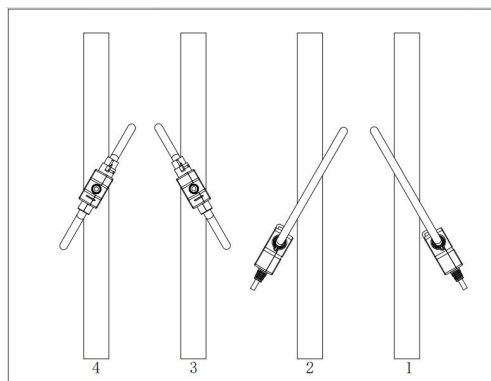

Figure 2

### Definition of Typical Values, Minimum Values, and Maximum Values

For specified constraints and safety conditions, it is essential to understand the meanings of minimum and maximum values, as well as typical values.

On the other hand, a typical value is part of a statistical distribution and can be defined using an interval with upper and lower bounds, along with the probability that a measurement falls within that interval.

Unless otherwise specified, TFY defines such intervals named "maximum" and "minimum" as intervals where the probability that sample values fall within them is 99.73%.

For a normal (Gaussian) distribution, this corresponds to the interval between  $-3\sigma$  and  $+3\sigma$ . If the "typical values" are not the obvious mean, these values are defined as defining the interval with a probability of 68.27%, equivalent to the range from  $-\sigma$  to  $+\sigma$  in the normal distribution.

The typical values, minimum values, and maximum values are all determined during the initial product characteristic testing phase.

### Naming and Coding

Example: TC-3-A1000-JD9.5-XD100-6-IN2.5-OUT0.15-003

Structural style	Number of coils	Rated measurement specifications	Coil cross-sectional diameter	Inner diameter of the coil	Coil color	Coil input signal Line length	The output signal of the integrator Line length	Output signal line terminal Subtype
TC	3	A1000	JD9.5	XD100	6	IN2.5	OUT0.15	003

English	Blue	Orange	Red	Green	Yellow	Gray	White	Black
Color Name	Blue	Orange	Red	Green	Yellow	Gray	White	Black
Color Number	1	2	3	4	5	6	7	8

Code	01	02	03	04	05	06	07	08	09
Terminal Model	RJ11	RJ12	RJ45	RJ12+RJ45	USB	10 Core Phoenix Terminal	4 Core Phoenix Terminal	10-pin Phoenix terminal + 4-pin Phoenix terminal	Cold-pressed tubular terminal

Code	10	11	12	13	14	15	16	17	18	19	20
Terminal Model	BNC	SMA	MMCX	N Public Head	Headphone earpiece	M8 Aviation Plug	M12 aviation plug	LEMO type	2.54 Terminal type	.....	.....

### According to the accuracy class specified in IEC 61869-10

Center conductor

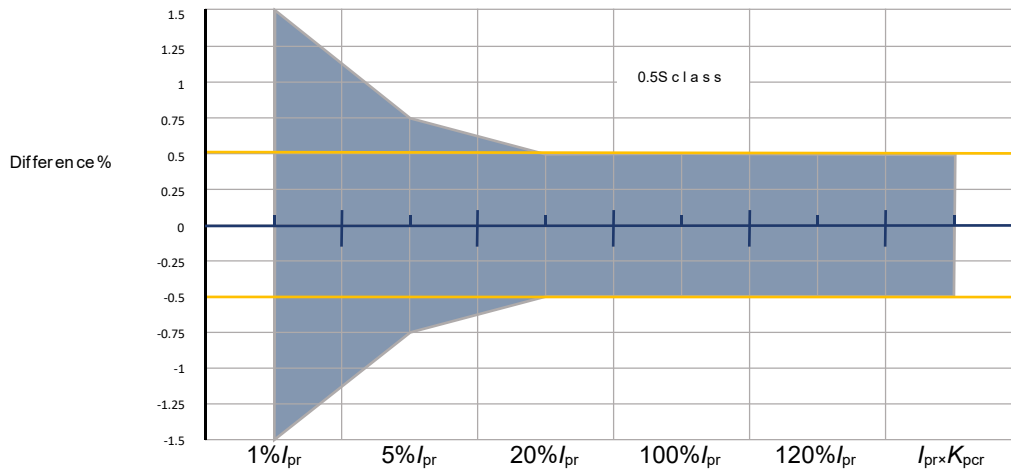

Accuracy class limits of IEC 61869-10



Accuracy Class Limitations of T-Series Rogowski Coils

Figure 3

## Terminology and Definitions

### Rated transformation ratio $k_r$

$k_r$  is the ratio between the rated primary current  $I_p$  and the secondary voltage  $U_s$ .

$$k_r = \frac{I_p}{U_s}$$

### Difference $E$

The liquidity ratio difference expressed as a percentage is defined as:

$$\varepsilon = \frac{k_r U_s - I_p}{I_p} \times 100\%$$

At this location:

$k_r$ : Rated voltage ratio

$I_p$ : Actual primary current

$U_s$ : Actual secondary voltage when  $I_p$  flows through

### Phase Difference $\Delta\varphi$

$\Delta\varphi$  represents the phase difference between the primary current and the ideal secondary voltage vector. For an ideal Rogowski coil, the vector direction is 90° leading.

When the secondary voltage phasor leads the primary current phasor, the phase difference is positive.

### Linearity $\varepsilon_L$

Linearity  $\varepsilon_L$  is the maximum positive or negative difference between the measurement point and the linear regression line, expressed as a percentage of  $I_p$ .

### Crosstalk Error $\varepsilon_{XT}$

Crosstalk error defines how external currents passing near a product affect its performance. The crosstalk error, expressed as a percentage, is given by the following formula:

$$\varepsilon_{XT} = \frac{S_{XT} - S_{ref}}{S_{ref}} \times 100\%$$

herein :

$S_{ref}$  : The sensitivity measured at the central position of the product;

$S_{XT}$  : The product sensitivity measured using an external conductor of at least 15 mm, perpendicular to and in contact with the Rogowski coil, with a current level equal to that of the internal conductor.

Size (unit: mm)

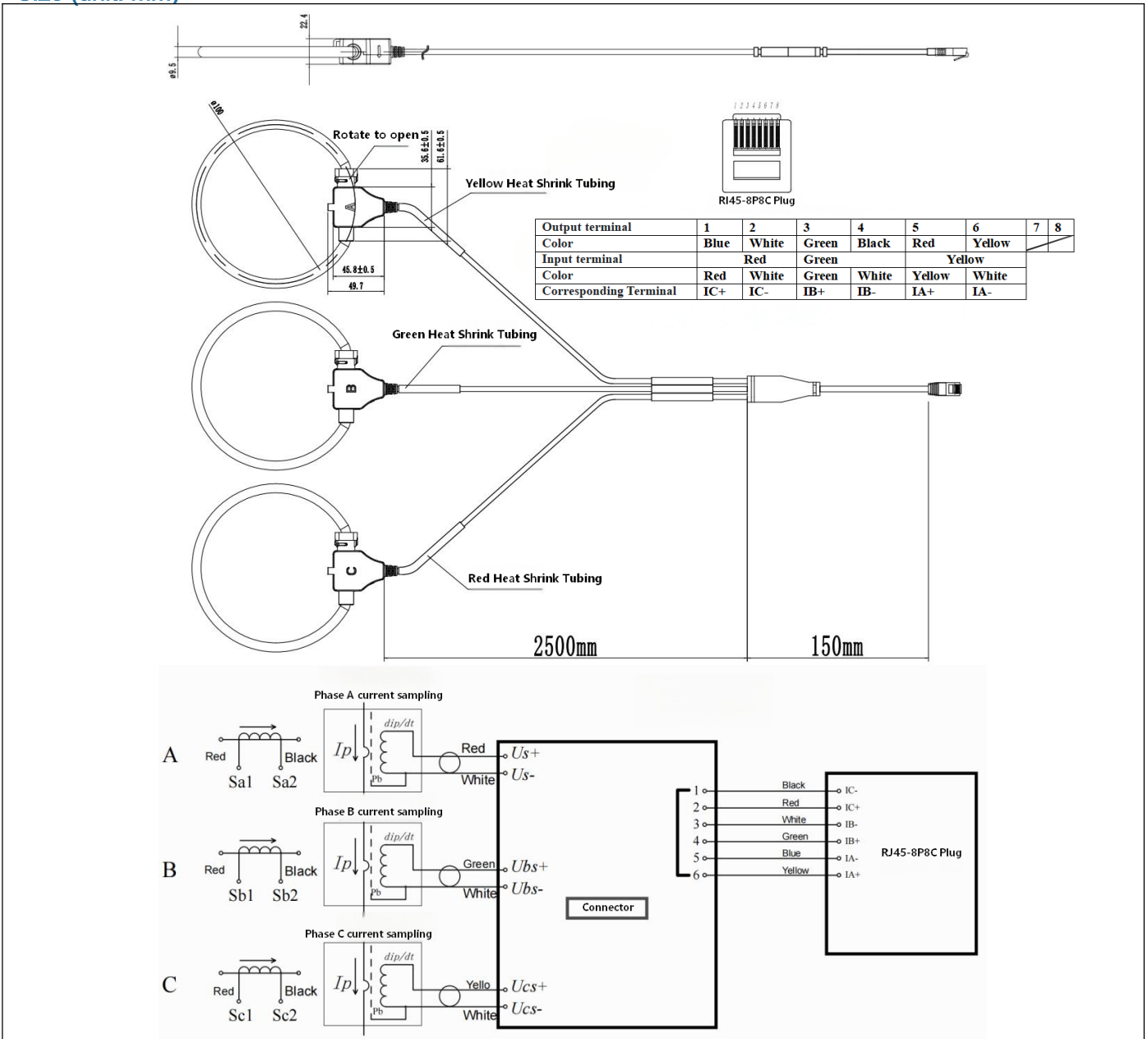

Figure 4

**Mechanical Properties**

- General tolerance: ±1 mm
- Signal line input length / Integrator signal output line length-----See Figure 4
- Output terminal-----See Figure 4

**Remarks**

- $U_s = U_{s+} - U_{s-}$  It is positive when the main current  $d_i / d_t$  increases in the arrow direction.
- Due to the small positional tolerance, this device does not require physical fixation around the main conductor. If the device is fixed, ensure that no mechanical stress is applied to the coil itself.
- Unless otherwise specified in the data table, installation must be performed in accordance with the product installation instructions. Please refer to the relevant documents available on our website:

<http://www.cn-tfy.com>.